

ZF-1 / AL. SENSOR REAR SINGLE GEAR

50213322P1

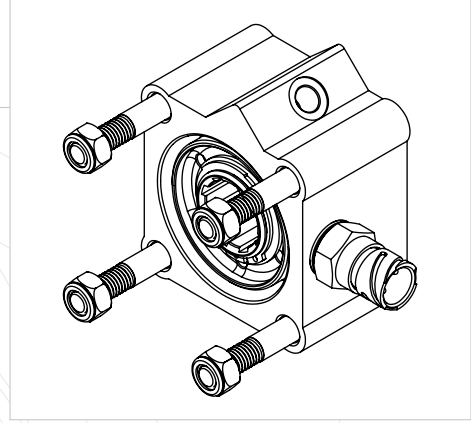

AIR INLET R 1/4"  
HAVA GİRİŞİ R 1/4"

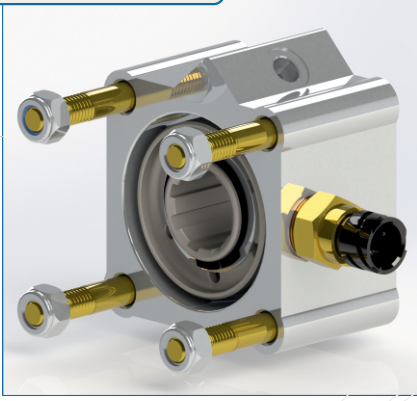
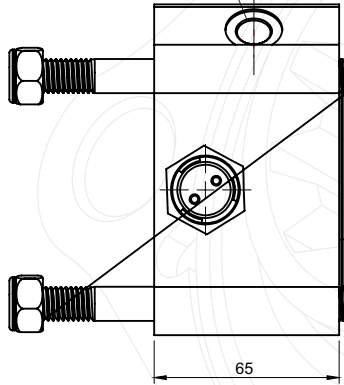

DIN 5462 8x32x35

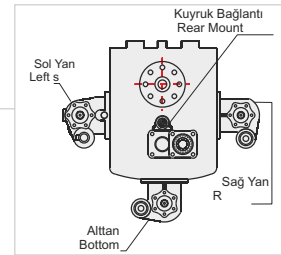
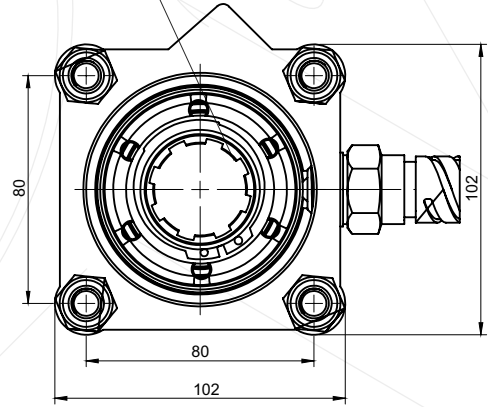

GENEL BİLGİLER/GENERAL DATA

P.T.O. KODU / P.T.O. CODE	50213322P1	
Tork / Torque	48,9 Kg <sub>m</sub>	479,5 Nm
Güç(1000 rpm) / Power	34,5 Hp	25,7 Kw
Dev Speed	513 rpm	513 rpm
Oran / Rat	1/1	1/1
Ağırlık / We	kg	lb
Bağlantı / Mount	Kuyruk	Rear
Kumanda / Control	Havalı	Pneumat
Dönüş / P.T.O. Rotat	Sağ - ISO	R

Ana Şanzıman / Gearbox	Kullanılan Bazı Araçlar / Used Veh
ZF16S251-221-151-150-130- ZF S5/AK/65-120-111-110-92- GP ZF S5/AK/6S-90-80-70-66- 65-55-50-42-36-35-ZF-ECOMIT 9S75-9S109-16S109 ZF NEW ECOSPLIT 16S1620TD- 16S1820TO-18S1820TO- 16S2220TD-16S220TO- 16S2520TO- 16S2023TDL	MAN / MERCEDES / BMC PROFESYONEL / FORD CARGO / CHRYSLER HINO / DODGE / FARGO / IVECO / DAF/ DAEWOO / RENAULT

Seçeceğ  
The rotat

.T.O. dönüş yönü

.T.O.

P.T.O. montaj ed  
F

.T.O.

POWER TAKE OFF

P.T.O.