

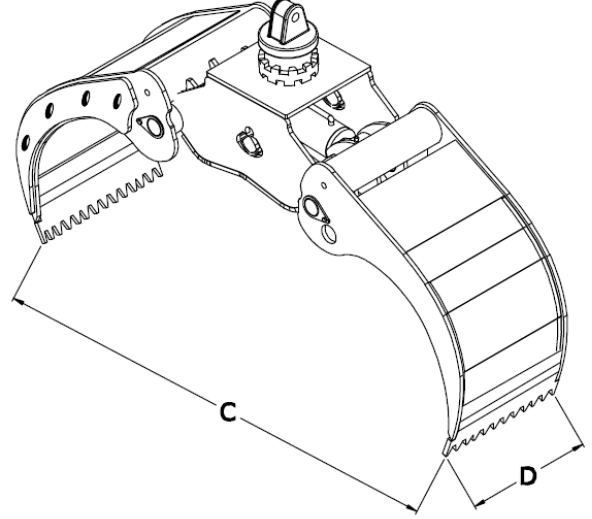

www.cnc-world.com

CNC
MOBILE AND INDUSTRIAL HYDRAULIC

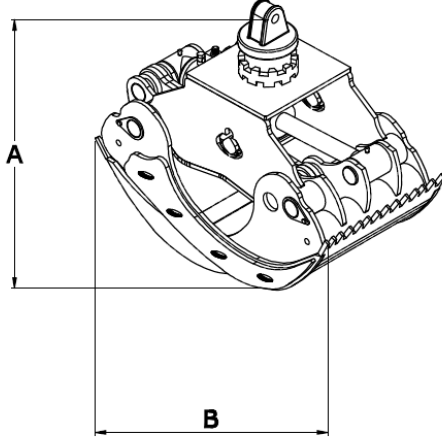

MODEL	Ağırlık Weight KG	Hacim Capacity Ton	Working Pressure Max Bar	A	B	C	D
MHT1	325	2	220	700	1050	1750	500

Teknik Özellikler / Technical Data

Kaldırma Kapasite / Lifting Capacity 2 Ton

Ağırlık / Gross Weight 325 Kg

Çalışma / Working Principle Hydraulic

Basınç / Working Pressure 220 Bar

K. Basınç / Closing 280 Bar

Rotatör / Rotation 270/360°

Tırnak Adedi / Tines 2

Tırnak Uçları / Nails Hardox 450