

50412321P0

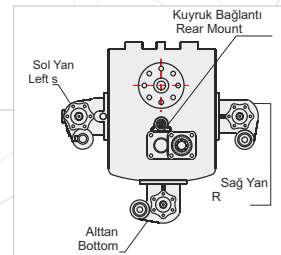
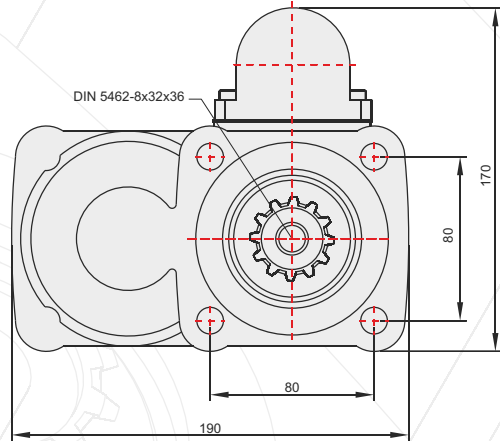
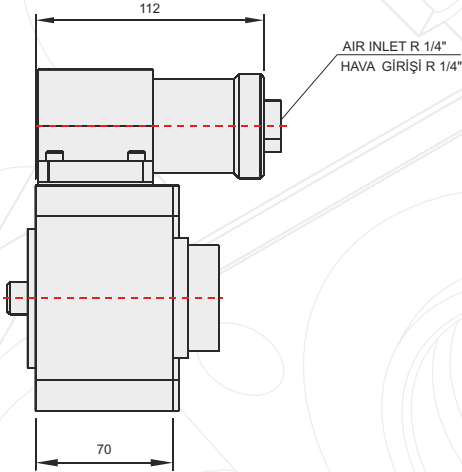
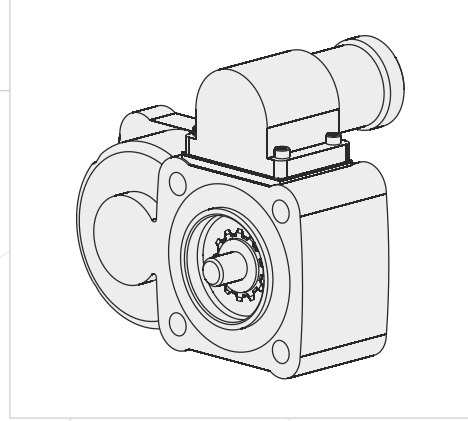

GENEL BİLGİLER/GENERAL DATA

P.T.O. KODU / P.T.O. CODE	50412321P0	
Tork / Torque	26,5 Kgm	260 Nm
Güç(1000 rpm) / Power	24,5 Hp	13,8 Kw
Dev Speed	675 rpm	675 rpm
Oran / Rat	1/1,2	1/1,2
Ağırlık / We	11 kg	24,4 lb
Bağlantı / Mount	Kuyruk	Rear
Kumanda / Control	Havali	Pneumat
Dönüş / P.T.O. Rotat	Sol - UNI	Left - UNI

Ana Şanzıman / Gearbox	Kullanılan Bazı Araçlar / Used Veh
EATON FS / FSO/H/V 4106-5206 A/B/H	180-167-620-622 BMC PRO / 220.26- 180 FATİH BMC 2520 FORD CARGO AS 950 / CHRYSLER 180.12-210-220 CD-320 MIDLUM RENAULT / FODEN 2000 / ERF E6.18 / 1415-1718 FORD 8.163-8.224-18.228 MAN