

since 1954



MOBILE & INDUSTRIAL HYDRAULIC

www.cnc-world.com

HYDRAULIC OIL COOLER
G SERIES

CAPACITY SPECIFICATIONS

2.



Product Models	Max. Flow (Lt/min)	Capacity (Kcal/h)
G0001	40	2000
G0005	80	5500
G0010	100	6000
G0020	120	12000
G0030	140	20000
G0040	160	25000
G0050	180	40000
G0060	220	60000

3. TECHNICAL DATA

	Fan Diameter	Fan Speed	dB(A) 1m	Voltage (V)	kW	Working Pressure (Bar)
G0001	155 - 155 - 160	750 - 750 - 700	51 - 51 - 50	12 - 24 - 230 - 400	0.04 - 0.04 - 0.05	25
G0005	195 - 195 - 200	2700 - 2700 - 2800	72 - 72 - 68	12 - 24 - 230 - 400	0.09 - 0.10 - 0.06	25
G0010	195 - 195 - 200	2700 - 2700 - 2800	72 - 72 - 68	12 - 24 - 230 - 400	0.09 - 0.10 - 0.06	25
G0020	245 - 245 - 250	2700 - 2700 - 2800	74 - 74 - 72	12 - 24 - 230 - 400	0.11 - 0.11 - 0.10	25
G0030	290 - 290 - 300	2700 - 2700 - 2800	74 - 74 - 72	12 - 24 - 230 - 400	0.18 - 0.18 - 0.19	25
G0040	345 - 345 - 350	2700 - 2700 - 2800	78 - 78 - 74	12 - 24 - 230 - 400	0.21 - 0.21 - 0.32	25
G0050	10"x2 - 10"x2 - 630	2700 - 2700 - 1500	74 - 74 - 89	12 - 24 - 230 - 400	0.15 - 0.15 - 0.43	25
G0060	14"x2 - 14"x2 - 630	2700 - 2700 - 1500	74 - 74 - 98	12 - 24 - 230 - 400	0.15 - 0.15 - 0.43	25

4. DIMENSIONS

	G0001	G0005	G0010	G0020	G0030	G0040	G0050	G0060
A	190	230	230	300	350	450	525	700
B	170	230	230	300	350	450	545	720
C	45	45	63	63	63	63	63	63
D	220	290	290	360	410	510	-	-
E	280	320	320	400	440	550	670	850
F	45	45	40	40	40	40	63	63
G	-	-	-	-	-	-	-	-
H	225	265	265	330	380	480	245	375
I	125	125	125	125	125	125	155	165
K	155	155	155	155	155	155	200	200
L	-	-	-	-	-	-	-	-
M	-	-	-	-	-	-	-	-
N(max)	12-24-172 230-400-217	12-24-172 230-400-217	12-24-187 230-400-232	12-24-187 230-400-237	187 242	187 257	182 237	197 297
O	1/2" BSP	1/2" BSP	1" BSP	1" BSP	1" BSP	1" BSP	1 1/2" BSP	1 1/2" BSP

DIMENSIONS OF COOLERS FROM G0001 - G0040

5.

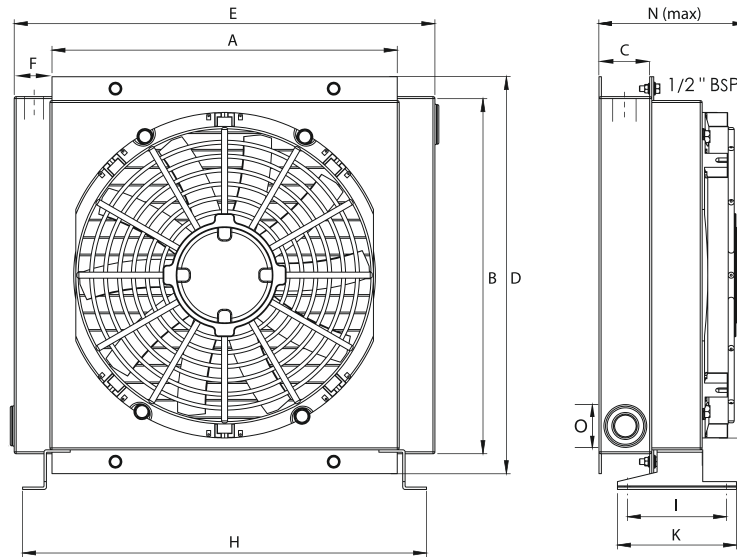

DIMENSIONS OF COOLERS FROM G0050 - G0060

6.

